



DSL-490 SERIES

NEW LED BEACON SERIES



PRODUCT BENEFITS

- Attractive design
- Multivoltage 10-30V
- Compact aluminum housing
- Impact resistant lens made of Polycarbonate
- IP67 Protection
- Multiple mounting concepts (flat, flexible, magnetic)
- EMC Approved (option for CISPR 25 Class 5)
- Can be synchronized with up to 4 beacons
- Universal mounting holes
- 4 Flashing Patterns (ECE approved)
- 12 Powerful LEDs
- Flexible base can absorb impacts

TECHNICAL SPECIFICATIONS

TECHNICAL DATA

Operating Voltage		10 V - 30 V DC			
Reverse Polarity Protection		Yes			
Max. Consumption		7,5W - 11W (depending on flashing frequency)			
Temperature Range		- 40°C to + 65°C			
Type of Mounting		Screw Fastening / Pipe Fastening / Magnetic Attach			
Material	Lens	PC			
	Housing	Aluminum			
Type of Protection		IP67			
Approvals	ECE		R65	R65	
			TA1	TB1	
			00	00	
	EMC	R10-06			
Type of Connection	Standard Versions	Open cable wires (Cable length 450mm)			

DIMENSIONAL DRAWING

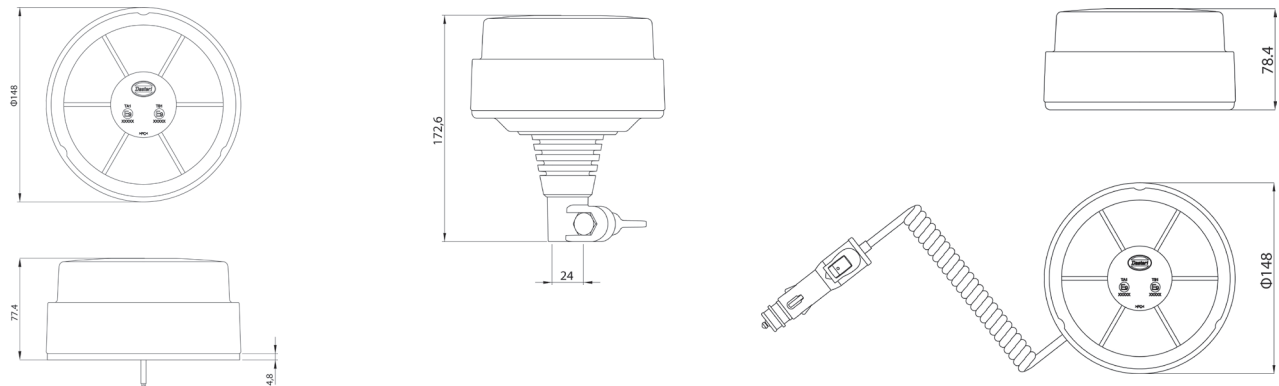

CODES SERIES DSL-490 OVERVIEW

Variants Ref. No.	Flat	Flexible	Magnetic	Amber	Red	Blue
DSL-490.05	•			•		
DSL-490.06	•				•	
DSL-490.08	•					•
DSL-490FL.05		•		•		
DSL-490FL.06		•			•	
DSL-490FL.08		•				•
DSL-490M.05			•	•		
DSL-490M.06			•		•	
DSL-490M.08			•			•